

PRESSURE REGULATOR

RP/10

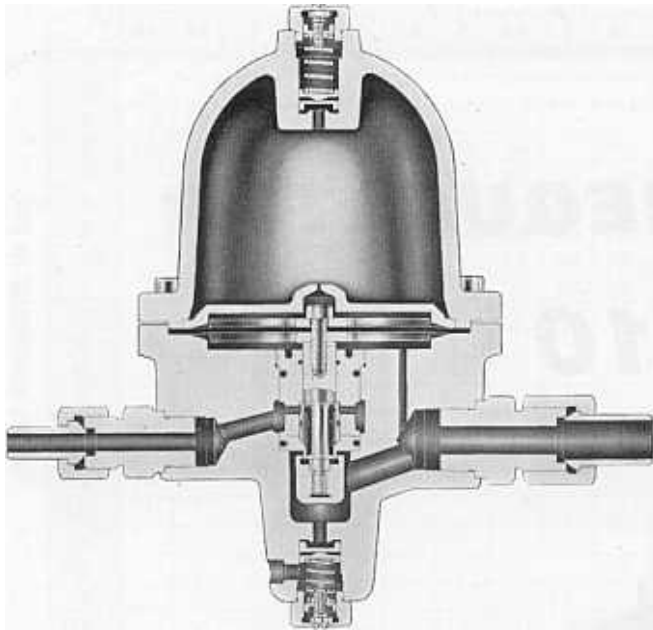

The regulator RP/10 can be used in the decompression stations which use the high pressure gas of the bottles, or the middle pressure one of the methane-pipes, as well as in the small and middle industries which use the earth gas for the feeding of small furnaces, in the ceramic industries, in the chemical and pharmaceutical industries.



- The diaphragm is made in rubber impregnated cloth, a material which permits a high specific pressure. For the purpose to make the operation possible with high differential pressures, the diaphragm has been protected with two strong steel plates.
- A spring operated safety valve, fitted in the delivery pipe, checks the adjusted pressure, safeguarding the device from eventual over-pressures. The safety valve is not sufficient to discharge all the delivery that the reducer can issue. Its task is the one to discharge the eventual escapes of gas due to imperfections of the tightness parts. For the purpose to avoid dispersions of gas in the permises in which the regulator is installed, said safety valve is supplied with a discharge that can be conveyed away.
- A spring operated safety valve, fitted in the bell, checks the adjustment pressure. This valve prevents that, owing to a wrong operation during the rating, the value of the pressure rises beyond a limit which is deemed dangerous.

OPERATION

The pressure (P_c) existing in the air-tight bell (C) operates on the diaphragm (D). The pressure (P_c) is balanced by the delivery pressure (P_v) which operates on the diaphragm (D) in the contrary direction.

The causes which can modify this balance are:

- a) Increase of the gas pressure in the inlet side.
- b) Reduction of the gas pressure in the inlet side.
- c) Increase of the request of gas.
- d) Reduction of the request of gas.

In the cases a) and b) an increase or a reduction of the pressure in the inlet side cause a reduction of the differential pressure between inlet and outlet side of the throttle valve, with a consequent variation of delivery.

In the first case, an increase of the pressure (P_m) causes an increase of delivery which, being superior to the absorption, aims to raise the pressure in the outlet side (P_v).

The difference of pressure that is thus formed between the bell (C) and the chamber (C_1), operating on the diaphragm (D), raises the shutter (V). The reduction of the useful section of passage which is its consequence, reduces the pressure in the outlet side (P_v), bringing it again to its initial rating value.

In the second case, a reduction of the pressure (P_m) causes a reduction of the delivery and therefore of the pressure (P_v).

The pressure (P_c), prevailing on the (P_v), causes a lowering of the diaphragm (D) and the consequent opening of the valve.

The value of the delivery increases until it reaches

SPECIFICATIONS

The main specifications of the pressure regulator for compressed gases type RP/10 are:

- Shutter with simple seat, balanced by a counter-thrust piston. This manufacturing peculiarity of the shutter permits to cancel, to the effects of the controlled pressure, the variations of the pressures in arrival.
- Perfect tightness at zero delivery. The adoption of gaskets in special synthetic rubber, resisting to the chemical action of hydrocarbons, allows a perfect closure with a minimum overload of pressure. On the contrary of what it may be thought, the gasket is not undergoing wear, as — being almost completely contained — it is not skimmed by gas. The method with which the gasket has been protected is a special peculiarity of our reducers.

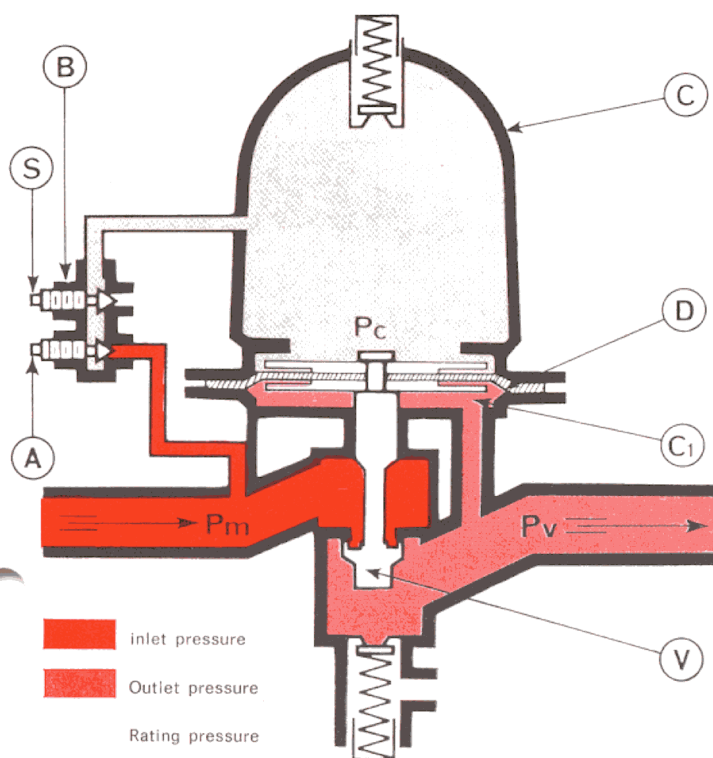

the requested quantity, and the pressure (P_v) is thus brought back to its initial value.

The cases c) and d) can be compared to the previous ones as, to the effects of the operation, an increase or a reduction of the absorption correspond to a reduction or to an increase of the pressure (P_m), respectively.

RATING

The rating operation consists in loading the bell (C) with a pressure sufficient to adjust the pressure in the outlet side (P_v) to the desired value. For information, we shall say that the pressure (P_c) of the bell is not exactly equal to the pressure of issue (P_v), but it is slightly inferior. This difference is caused by the necessity to balance the weight of the mobile device, which operates in the direction of the pressure (P_c).

The rating is made by means of the small block (B). Two valves are housed in the block: the lower one for the loading of the bell, and the upper one for the discharge.

The gas for the loading of the bell is taken from the inlet pipe.

The rating of the device is made during the operation.

By means of the purposely made spanner, the small valve (A) is opened, reading in the same time the value of the pressure on the pressure gauge fitted on the outlet pipe; when this value is reached, the valve is fixed in its closed position.

Should the pressure increase beyond the desired value, the bell is discharged by means of the small

valve (S), of the quantity of gas in excess.

It is possible that, during the rating operation, the safety valves built in the regulator begin to operate. This can happen either because the pressure has reached a value superior to the allowed one, or owing to the want of adjustment of said devices. It is advisable to verify, when starting the device, that the safety valves are rated at the requested value.

The discharge pressure must be superior, of about 10%, to the delivery pressure.

The rating is made with the assistance of a standard screw-driver.

The first operation is the one of bringing the pressure in the outlet side to the desired value of delivery. In this moment it has to be operated on the adjustment screw until a slight breathing through the valve is obtained.

When the rating is made, the delivery pressure is brought back again to the standard value.

In these conditions the safety valves must be perfectly closed.

To increase the delivery pressure, the adjustment screw must be turned in an anti-clockwise direction; operating instead in a clockwise direction the pressure is reduced.

In order to make correctly the rating of the device, the cutting-off valve in the outlet side of the regulator should not be completely closed.

It is necessary that a small quantity of gas flows either into the pipe or outside, to allow the emptying of the outlet connection should the bell be discharged.

If, owing to the exigencies of the plant, the cutting-off valve cannot be opened, it is necessary to create a little escape outside, loosening, for example, the connection of the pressure gauge in the outlet side.

We advise to make these operations with the necessary cautions, especially when the pressure in the inlet side is very high.

The pressure in the outlet side must never surpass the maximum allowed limit.

WARNINGS

So that the pressure regulator is in the condition to reach the maximum operation services, the gas must be filtered and heated. The presence of dust or of other solid impurities may, in the time, wear the most delicate parts of the device, compromising its good operation. In its expansion, the gas undergoes a reduction of temperature which, in some cases originates the passage to the solid state of the hydrates contained in it. It is therefore necessary to heat the gas at a sufficient temperature, in order to prevent this trouble. When the plant is composed by two regulators operating in parallel, before making rating operations on one of them, it is advisable to ascertain that the other is perfectly isolated. A computer-pressure in the outlet side superior of 0,5 bar to the rating one can damage the device in a serious way.

